

CERTIFICATION



HACCP International



ISO9001

# ICE MATE



## SRM-60A

### ICE MAKER

ICEMATE is committed to bringing high-efficiency / energy-saving, and high quality ice-making product to people who have dreams and desire to create their own business with the best scientific technology and manufacturing technology.

#### DICE

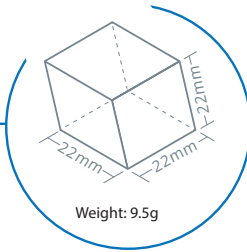

#### KEY FEATURES

##### SAFETY AND HYGIENE ASSURED ICE MACHINE



NSF Certified Material for Bin and Scoop



Detachable Parts for Easy Cleaning



Air Filter Prevent Dust from Entering



Stainless Steel

##### ENERGY & WATER SAVING, QUIET OPERATION



Energy & Water Saving, Quiet Operation

##### EASY MAINTENANCE



IoT



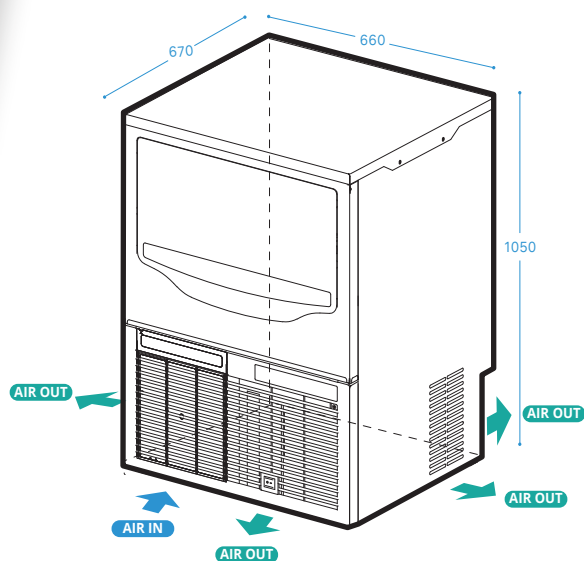

TOP SIDE

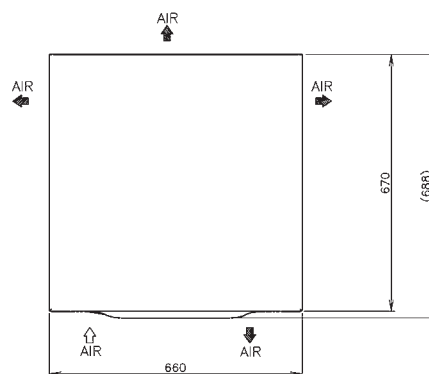

FRONT SIDE

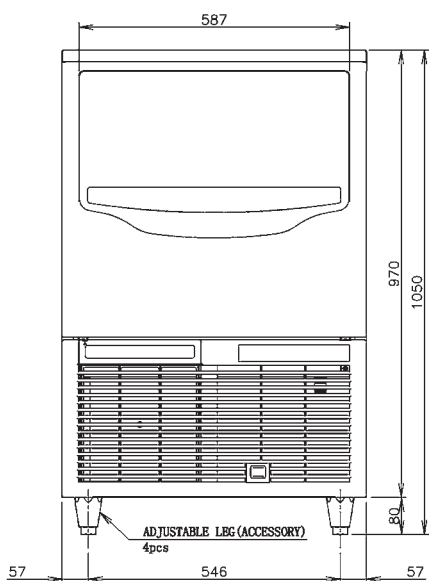

RIGHT SIDE

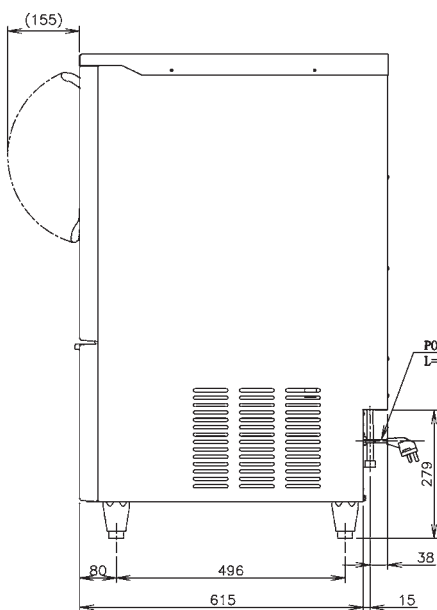

BACK SIDE

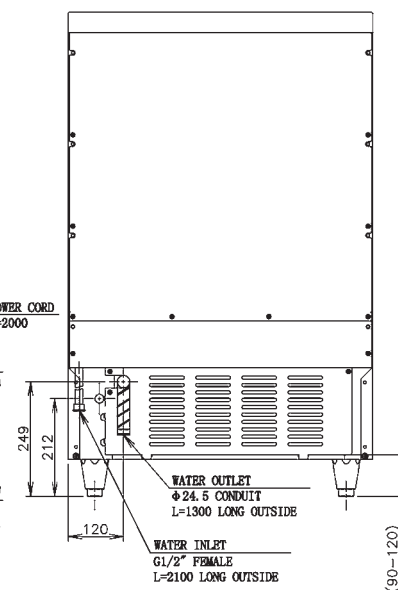

SPECIFICATIONS

Ice Dimensions (W x D x H)	22 x 22 x 22 mm
Outside Dimensions (W x D x H)	660 x 670 x 1050 mm
Package Dimensions (W x D x H)	Carton: 785 x 860 x 1100 mm
Weight (Net / Gross)	58 kg / 65 kg
Amperage / Starting Amperage	2.5A / 14.0A
Electrical Consumption	(AT32°C / WT21°C) 370 W
Refrigerant Charge	R134a / 220g
Ice Storage Capacity	Maximum 31.4kg
Ice Production per 24H	(AT10°C / WT10°C) Approx. 65 kg (AT21°C / WT15°C) Approx. 60 kg (AT32°C / WT21°C) Approx. 50 kg

Water Consumption per 24H	(AT32°C/WT21°C) 0.11m <sup>3</sup> (2.2L / kg Ice)
Ice Production Freeze Cycle Time	(AT21°C/WT15°C) 18 min
Ice Production per Cycle	(AT21°C/WT15°C) Approx. 0.81kg / 80 pcs

OPERATING CONDITIONS

Voltage Range	198 - 254 V
Ambient Temperature	5 - 38°C
Water Supply	5 - 32°C
Water Supply Pressure	0.07 - 0.55 Mpa (0.7 - 5.5 bar)
Supply Voltage	1/220 - 240V / 50Hz



**HOSHIZAKI**

**HOSHIZAKI (THAILAND) LIMITED**

No. 99 CP Tower North Park building 9th Floor, Zone D1 Soi Ngamwongwan 47 Intersection 42, Thung Song Hong Subdistrict, Lak Si District, Bangkok 10210 Thailand. TEL +66 2 005 9980 | FAX +66 2 516 2646  
<https://hoshizaki-sea.com>